

CAD Drafting

Spokane Community College

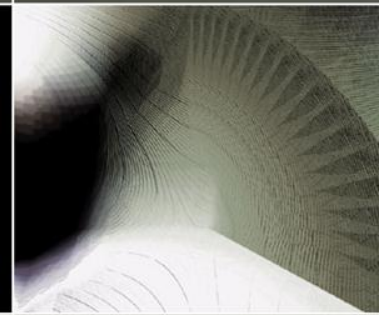

2-Dimensional CAD

Software like AutoCAD is used to draw the basic shape

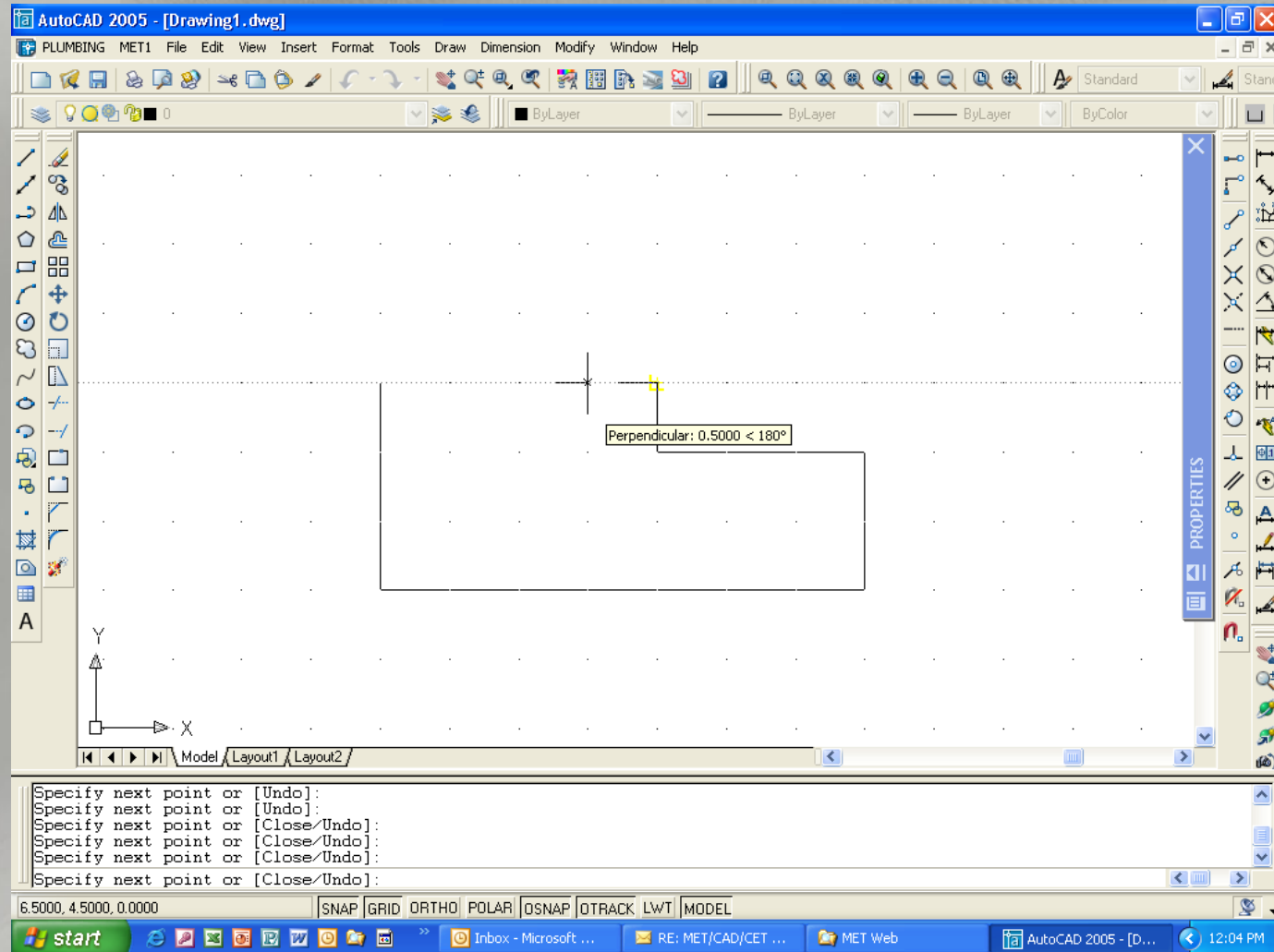

Dimensions and details are added to the drawings

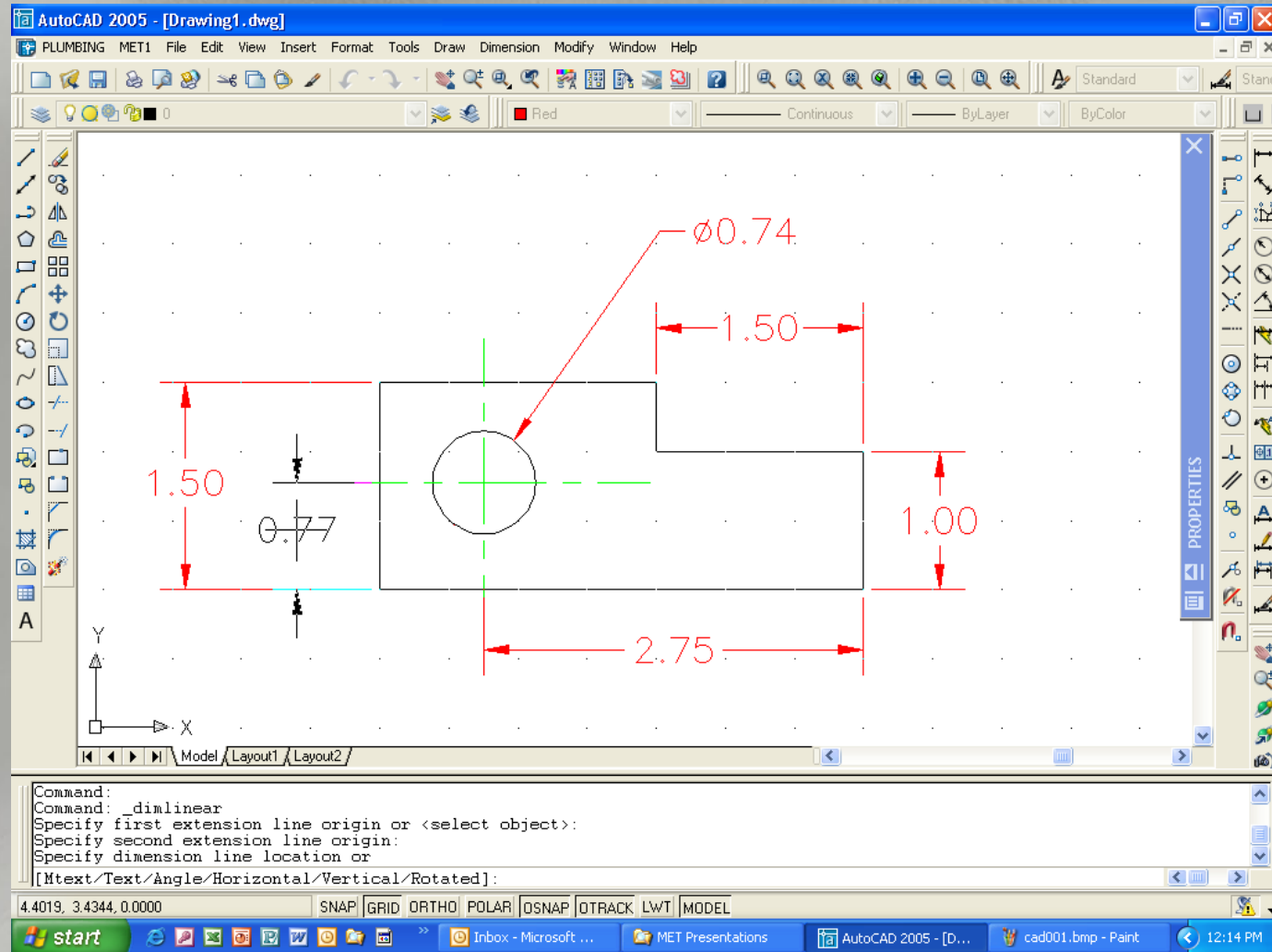

2-Dimensional CAD

Sample AutoCAD drawings

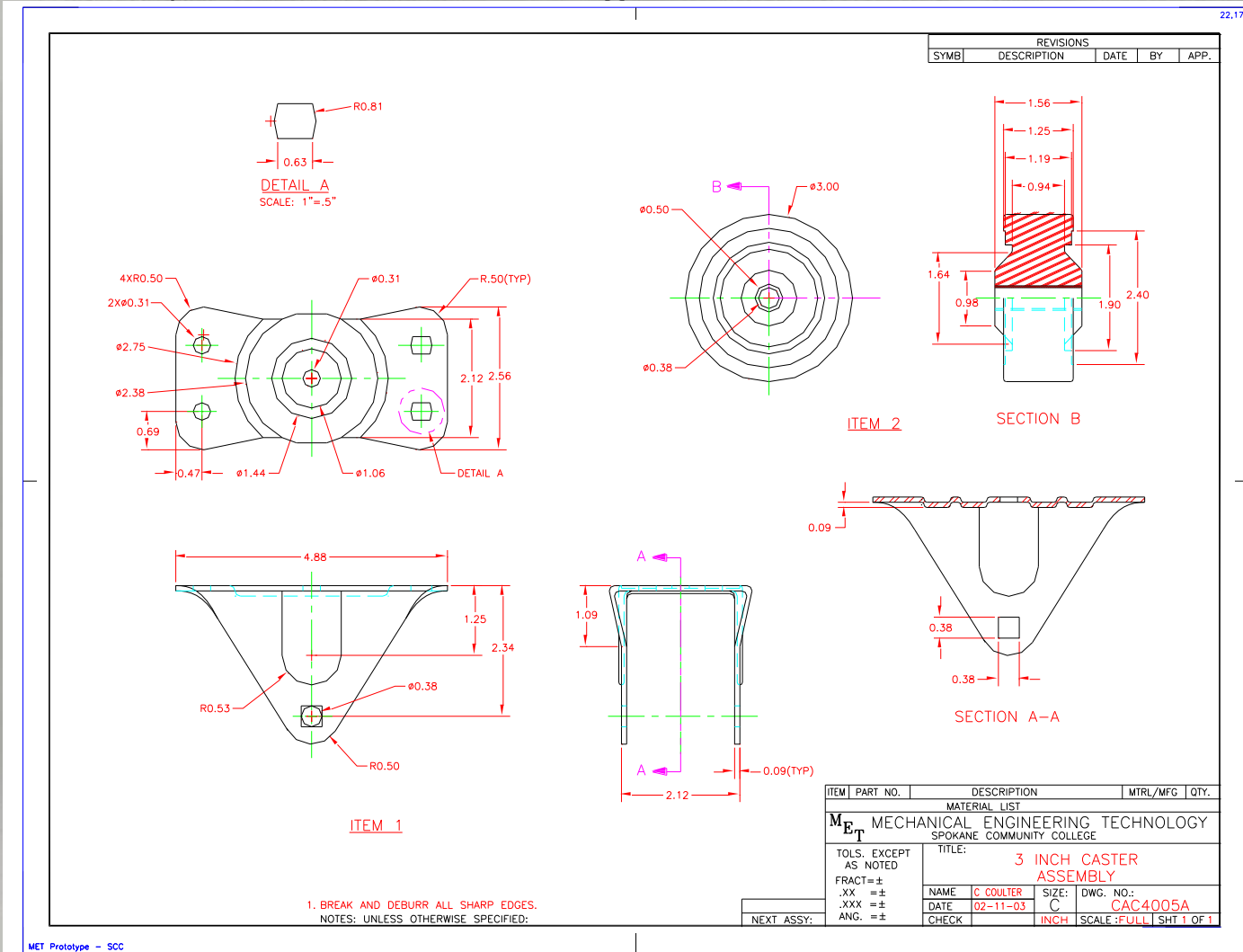

2-Dimensional CAD

Sample AutoCAD drawings

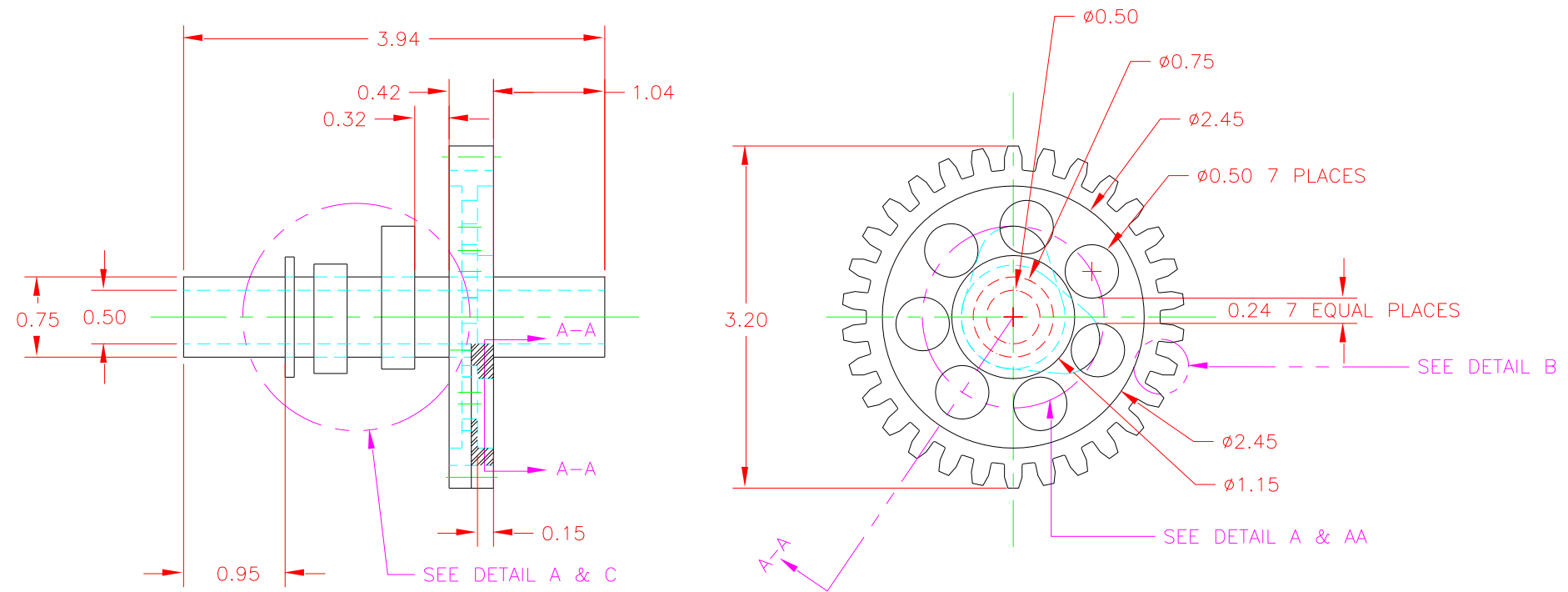

2-Dimensional CAD

Sample AutoCAD drawings

